

A plasma-shielded, miniature Rogowski probe

E. Torbert, I. Furno, and T. Intrator

P-24 Plasma Physics, Los Alamos National Laboratory,

Mail Stop E526, Los Alamos, NM 87545, USA

(Dated: May 10, 2003)

Abstract

The design and first results from an electrically isolated and plasma-shielded Rogowski probe, used in the Reconnection Scaling eXperiment (RSX), are presented. The probe is designed to withstand extreme thermal shock, plasma corrosion and be vacuum sanitary, which is accomplished with a machinable boron nitride shell. The novel miniature design, with an inner detecting area of 0.79 cm^2 , allows accurate position detection of plasma current channels with $\approx 2 \text{ cm}$ radius and to measure local current density profiles. The temporal resolution ($< 1 \mu\text{s}$) is sufficiently high to resolve the dynamic evolution of RSX plasma current channels.

I. INTRODUCTION

Rogowski probes¹ have been used for decades for non-invasive current measurements when other probes, such as current transformers, are impractical. The current measurement is performed by encircling a current, I , with a helically wound coil of wire. For a coil of uniform cross-sectional area A , provided that the magnetic field, B , generated by the current I varies little over one turn spacing ($\nabla B/B \ll n$), the voltage induced in the Rogowski probe can be expressed as

$$V(t) = -\mu_0 A n \frac{dI}{dt} \quad (1)$$

where n is the number of coil turns per unit length and μ_0 is the vacuum magnetic permeability.

Rogowski probes are especially useful in pulsed power environments, where electrically isolated probes are needed. One such experiment is the Reconnection Scaling eXperiment (RSX)² at Los Alamos National Laboratory, in which plasma current channels approximately several centimeters wide with current densities up to 75 A/cm² are driven for a duration of up to 8 ms in an evacuated vessel. Typical RSX plasma parameters are electron temperatures $T_e \approx 12$ eV and electron densities $n_e \approx 10^{14}$ cm⁻³ leading to a power flux as high as 500 W/cm². Characterization of plasma channels, including current density profile, channel width, and channel position, requires a probe that can be directly inserted into a hostile plasma environment. This poses severe restriction on the materials for the probe that need to be non-magnetic, vacuum sanitary, mechanically and thermally durable.

Existing Rogowski probes are physically large (from 9 to 20 cm diameter) and their technology is not suitable for insertion into RSX plasmas. In Turner and Hofsjager's exploding wire experiments³, a Rogowski coil 9 cm in diameter was electrostatically shielded with an aluminum housing, but no protection from the exploding wire was needed. Pellinen used a polyethylene envelope to shield a Rogowski coil with a 10 cm diameter from the electron beam and charge pickup, and, in later designs, also shielded the coil inside an aluminum housing, but neither shield is vacuum and plasma safe^{4,5}.

In this paper, the design and first results from an electrically isolated and plasma-shielded miniature Rogowski probe, used to characterize plasma current channels in the RSX device are presented.

II. PROBE DESIGN AND CALIBRATION

The requirement for insertion of the Rogowski probe into RSX plasmas severely constrains the design of the probe. In particular, the detecting coil must be electrically insulated from the plasma to prevent plasma current from flowing directly into the detecting circuit. Detailed design features of the Rogowski probe are shown in Fig. 1. Electrical insulation is obtained by placing the detecting coil inside a Carborundum⁶ boron nitride (BN) cylindrical housing. The BN housing is vacuum sanitary at 10^{-7} torr, corresponding to the base pressure inside the RSX vessel, and robust to thermal and mechanical shocks. For the present design and depending on plasma conditions, a total heat load as high as 100 J can be delivered to the BN container resulting in a modest temperature increase of approximately 125° C over 10 ms. The housing is machined as two halves of a container out of hot pressed (HP grade) BN which has no high atomic number binder materials that could contaminate the plasma. The minimum thickness of the housing wall is 1.5 mm and the detecting area has a 1 cm inner diameter. The ratio of the area of detection to the area of obstruction of the probe is limited by the technical difficulty in machining thinner walls.

The toroidal detecting coil consists of a single layer helical winding with an inside return loop to cancel the net single turn formed by the solenoid windings. Thus, the output signal is generated only by the turns circling the toroidal magnetic flux created by axial currents. The coil wire (0.13 mm diameter) is manually wound around a Viton O-ring with cross section diameter of 1.8 mm. A slit in the O-ring allows the placement of the single return loop. The helical coil has a length of 4.3 cm with a total of 240 turns resulting in $An = 1.42 * 10^{-2}$ m \times turns. The resistance of the coil is 2.1Ω and the inductance is $1.6 \mu\text{H}$. A manual procedure to wind the detecting coil around the O-ring is chosen because it is less time intensive and cheaper than machining grooves into a rigid former as suggested by Ramboz⁷.

Under pulsed power conditions in the RSX device, rapid current changes are often accompanied by rapid voltage changes. These can produce capacitively coupled common mode current which can significantly disturb the measurement process. In order to reduce this undesired effect, a shield of non-magnetic, stainless steel SS304 foil (0.05 mm wall thickness), in a toroidal shape, is placed around the detecting coil inside the BN container as schematically shown in Fig. 1. The SS shield reduces capacitive coupling between the plasma and

the detection coil and, for frequencies below 100 MHz, results only in a small attenuation of the detected magnetic flux (the skin depth of stainless steel at 100 MHz is approximately 0.044 mm).

The output of the detecting coil is transmitted by an in-house made triaxial cabling system in which the outermost conductor (a copper tube, 2.4 mm diameter and 0.7 mm wall thickness) acts as common ground for both signal leads to minimize the effect of capacitively coupled common mode currents. The copper tube is spot-welded to the toroidally shaped SS shield inside the BN container to provide electrical continuity of the shield. The innermost coaxial cable consists of one 32 gauge, teflon insulated wire, with 0.15 mm Teflon insulation, inserted inside a demagnetized SS304 hypodermic needle (1.2 mm diameter , 0.13 mm wall thickness).

In Fig. 2, the assembly to insert the Rogowski probe inside the RSX vessel is shown. A pyrex tube provides electrical insulation between the triaxial cabling system and the plasma. A BN washer, Fig. 1, is used to seal the pyrex tube entry into the BN container. A 1/4" stainless steel tube slides inside a Swagelok fitting and holds the pyrex tube. A vacuum seal is provided by a Swagelok fitting attached to a 1/2" stainless steel tube which houses the pyrex tube. When the probe is fully retracted, a gate valve (not shown here) provides vacuum isolation from the RSX chamber. The 1/4" tube is connected to a probe cup, Fig. 2, where the leads of the Rogowski coil are attached to BNC connectors. The 1/4" stainless steel tube is grounded to common ground of the two leads at the probe cup. The entire assembly is designed to be modular, utilizing off the shelf parts, resulting in a high degree of flexibility and minimum cost of the probe.

In the present design, no ferromagnetic materials are used in the construction of the probe. This results in an amplitude-linear device that can be calibrated at relatively low currents (≈ 0.1 A) and used with confidence at high currents (≈ 100 A) eliminating the need of costly calibrations.

The calibration is performed on the entire assembly of Fig. 2. The Rogowski probe is excited by a sinusoidal current (40 mA peak-to-peak amplitude and frequency f) threading the coil. The output voltage, U_p , between the two ground referenced leads and the driving current, I , are monitored with a digital oscilloscope. The transfer function $H = U_p/(sI)$, where $s = 2\pi if$, is measured in the frequency range $400 \text{ Hz} \leq f \leq 6 \text{ MHz}$ and then extrapolated to 0 Hz to derive the effective An factor in Eq. 1. As the calibrating wire is

moved inside the detection area of the Rogowski, a maximum variation of 10% is measured at frequencies below 1 MHz. In Fig. 3, amplitude and phase of the measured transfer function are shown together with those obtained from an equivalent second order probe model as sketched in Fig. 4. The model is chosen to include non-ideal effects such as the capacitance of the cable and coupling to the shield, resulting in a transfer function given by

$$\begin{aligned}
 H &= \frac{U_p}{sI} \\
 &= \frac{\mu_0 An}{1 + s(L_s/R_s + R_p C_p) + s^2 R_p C_p (L_p/R_p + L_s/R_s)}
 \end{aligned}
 \tag{2}$$

where the symbols correspond to those in Fig. 4. Perfect coupling is assumed between the detecting coil and the shield in deriving Eq. 2.

The measured transfer function is fitted to the transfer function in Eq. 2 by varying the free parameters An and L_s/R_s . The best fit is found for $An = 1.37 * 10^{-2}$, which agrees within 5% with the An factor estimated from the geometry and number of turns of the detecting coil, and $L_s/R_s = 50$ ns. This last value represents an estimate of the delay time of the coaxial transmission line which, in the present design, limits of the probe bandwidth to ≈ 3 MHz. The two transfer functions in Fig. 3 show a good agreement for frequencies below 1 MHz. There are, however, discrepancies at frequencies above 1 MHz where other spurious parasitic effects not considered in the model of Fig. 4, such as the capacitive coupling between the probe and the shield, play an increasing role.

III. FIRST EXPERIMENTAL RESULTS

RSX is a device for studying three-dimensional magnetic reconnection in both collisional and collisionless laboratory plasmas². Presently, RSX is equipped with four plasma guns radially inserted into a linear vacuum vessel (20 cm radius, ≈ 4 m length) allowing the injection of parallel current channels along the axial, z , direction of the device. Each plasma gun contains a miniaturized plasma source (0.79 cm² gun nozzle) in which a hydrogen plasma is produced by an arc discharge between a molybdenum anode and a cathode. A set of 12 identical coils surrounding the vessel provide an axial magnetic field (0 – 0.1 T) confining the plasma. When the arc anode is negatively biased with respect to an external anode, a fraction of the arc current is diverted towards the external anode as plasma current. The

external anode is a 20 cm square stainless steel plate and can be moved along the RSX vessel to modify the length of the current channel. The duration of the bias discharge can be manually varied from a few μs to approximately 8 ms. By varying the external bias voltage V_{bias} , the total injected plasma current can be varied (0 – 1 kA) independently of the axial magnetic field. The current flowing at the external anode, I_{ext} , is monitored by a Pearson current transformer during each discharge.

The Rogowski probe is inserted into the RSX vacuum vessel through a flexible bellows using the assembly schematically shown in Fig. 2. This allows two-dimensional scanning in the plane perpendicular to the axis of the device and characterization of the current channel profile.

An illustration of the Rogowski probe performance is presented in Fig. 5 showing measurements obtained from a single plasma gun discharge with the probe positioned in the center of the current channel. The gun nozzle and the probe are located at, respectively, $z = 0$ and 100 cm. The current through the Rogowski, Fig. 5(b), is monitored during 2 ms when the external bias is switched on and plasma current is driven towards the external anode as seen in the temporal evolution of I_{ext} in Fig. 5(a). The Rogowski signal is low-pass filtered with a Butterworth filter at 20 KHz in order to suppress high frequency noise oscillations whose physical origin is presently under investigation. Radial profiles of the current, $I_{Rogowski}$, flowing through the Rogowski aperture are measured at the same axial position for three different bias voltages. In Fig. 6, time-averaged profiles in a 500 μs time window, indicated in Fig. 5 by dashed lines, are shown by solid lines as V_{bias} varies from 20 to 200 V. The error bars are calculated from the common mode current between the two leads of the Rogowski probe.

In Fig. 7, these profiles are unfolded into a plasma current density profile, $J(r)$, given by the analytical expression

$$J(r) = \frac{J_0 r_0^4}{(r^2 + r_0^2)^2} \quad (3)$$

The parameters J_0 and r_0 (listed in the inset in Fig. 7) are determined by a least square fit of the measured total current and the total current calculated from Eq. 3. The current threading the Rogowski probe, as calculated from the profiles in Fig. 7, is shown in Fig. 6 by dashed-dotted lines and is in good agreement with the experimental measurements. The total current driven at the external anode also closely compares (within 10% for $V_{bias} = 200$

V) with the total current as calculated from the profiles in Fig. 7.

IV. CONCLUSIONS

A vacuum sanitary, thermally and plasma shielded, electrically isolated Rogowski probe proves to be an exceptionally valuable diagnostic in the RSX pulse powered plasma environment. The probe is used to detect the position of plasma current channels with ≈ 2 cm radius and to measure local current density profiles. The temporal resolution ($< 1 \mu\text{s}$) is sufficiently high to resolve the dynamic evolution of RSX plasma current channels. In view of the encouraging results obtained during these preliminary experiments, a new Rogowski probe of identical design is being installed on the RSX vessel and used to perform experiments with two simultaneous plasma guns. Future plans include a the design of a smaller BN container to increase the spatial resolution and reduce the disturbance of the probe inside the plasma.

V. ACKNOWLEDGEMENTS

This work was supported by the *Los Alamos Laboratory Directed Research and Development - Exploratory Research* program.

¹ W. Rogowski and W. Steinhaus, Arch. Elektrotech. **1**, 141 (1912).

² I. Furno *et al.*, Rev. Sci. Instrum. **4**, 141 (2003).

³ G. R. Turner and I. W. Hofsajer, in *Proceedings of the Conference: 1999 IEEE Africon. 5th Africon Conference in Africa* (1999), vol. 26B, p. 759.

⁴ D. G. Pellinen and P. W. Spence, Rev. Sci. Instrum. **2**, 1699 (1971).

⁵ D. G. Pellinen, Arch. Elektrotech. **51**, 1535 (1983).

⁶ Saint-Gobain Advanced Ceramics Corp. Boron Nitride, 168 Creekside Drive Amherst, NY USA 14228, URL <http://www.carbobj.com/>.

⁷ J. D. Ramboz, IEEE Transaction on Instrumentation and Measurements **45**, 511 (1996).

⁸ Varian Vacuum Technologies, 121 Hartwell Avenue Lexington, MA 02421 USA, URL <http://www.varianinc.com/>.

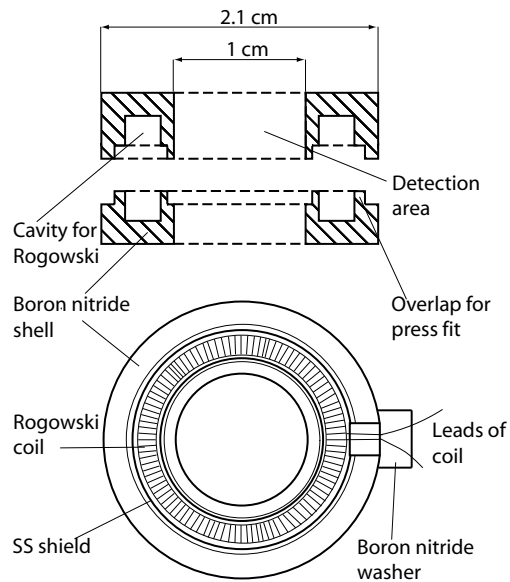

Figure 1: E. torbert, et al., A plasma-shielded, miniature Rogowski probe

FIG. 1: Schematic view of the BN housing for the detecting coil. The cross-section shows the cavity where the coil is inserted. The outer and inner edges on both halves of the boron nitride shell are stepped to overlap and seal the container. The Rogowski coil is shielded by a toroidally shaped stainless steel shield (0.05 mm thickness). The BN washer is used to seal the pirex tube entry on the assembly in Fig. 2 into the BN container.

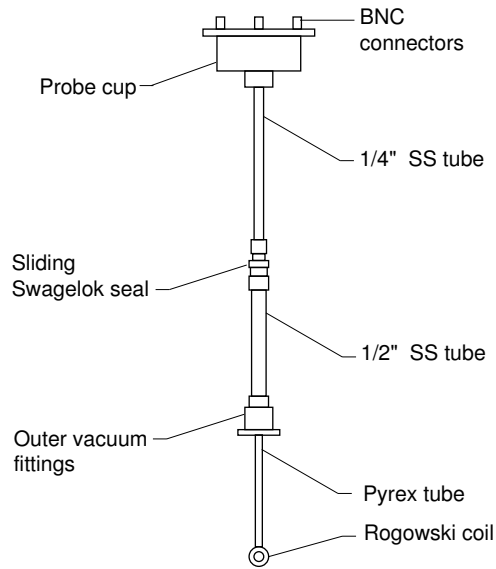

Figure 2: E. Torbert, et al., A plasma-shielded, miniature Rogowski probe

FIG. 2: The typical design for the assembly to insert the Rogowski probe into the RSX vacuum vessel. The sliding Swagelok seal allows for radial displacement of the probe, while the 1/2" stainless steel tube provides a "garage" for the retracting pyrex tube.

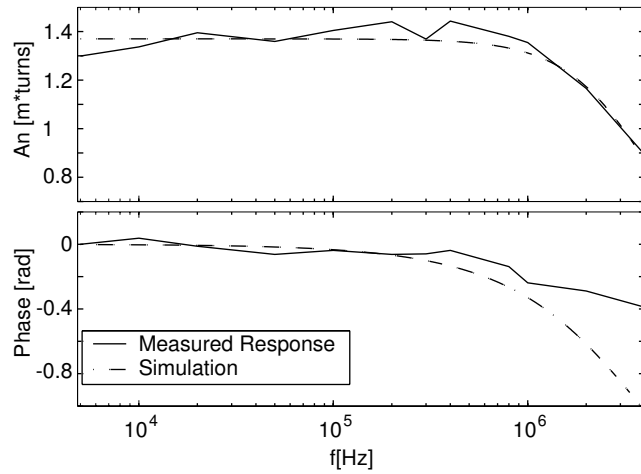

Figure 3: E.Torbert, et al., A plasma-shielded, miniature Rogowski probe

FIG. 3: Frequency response of the Rogowski probe. Solid line: experimental measurements. Dotted line: fitted second-order transfer function given by Eq. 2.

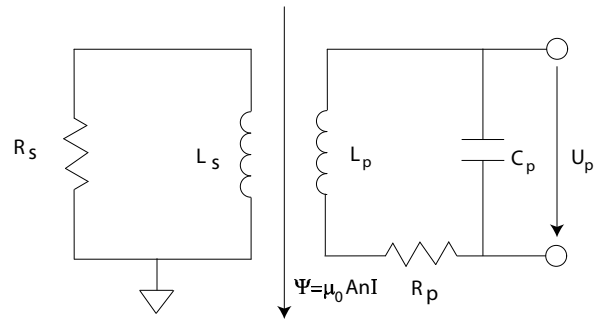

Figure 4: E.Torbert, et al., A plasma-shielded, miniature Rogowski probe

FIG. 4: Equivalent second-order circuit of the Rogowski probe.

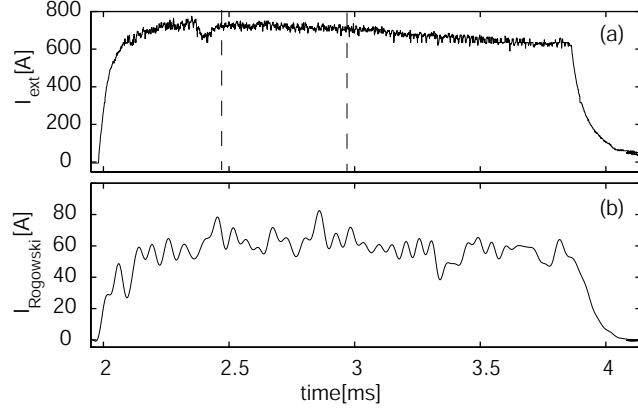

Figure 5: E.Torbert, et al., A plasma-shielded, miniature Rogowski probe

FIG. 5: Time evolution of a RSX discharge using a single plasma gun. The external bias is switched on at $t \approx 2$ ms, and plasma current is driven to the external anode. The current at the external anode (a) is monitored by a Pearson transformer. The Rogowski probe is located in the center of the current channel at $z = 100$ cm from the gun nozzle and the temporal evolution of the current is shown (b).

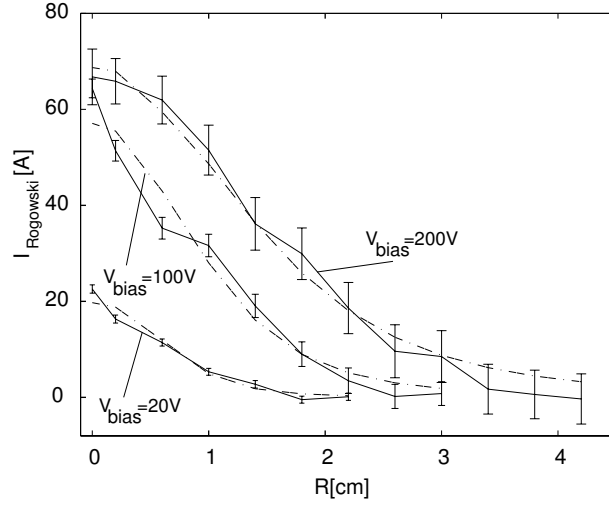

Figure 6: E.Torbert, et al., A plasma-shielded, miniature Rogowski probe

FIG. 6: Radial profiles of the current threading the Rogowski probe for different values of applied external voltage V_{bias} . The profiles are time-averaged in the time window indicated by dashed line in Fig. 5. Solid line: experimental measurements. Dashed-dotted line: current threading the Rogowski probe as calculated from the radial current density profiles in Fig. 7.

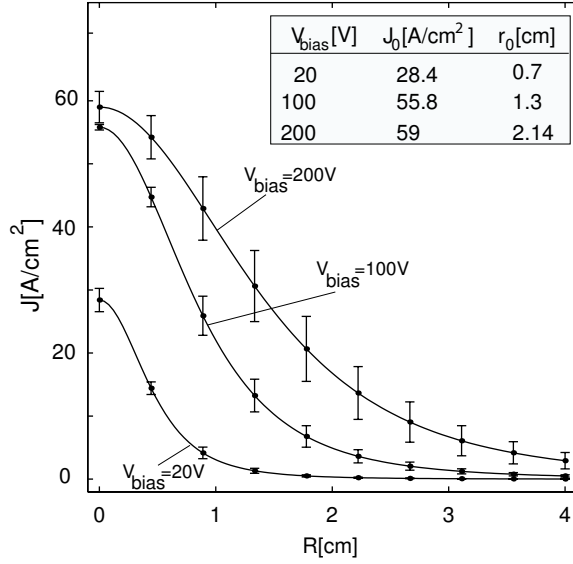

Figure 7: E. Torbert, et al., A plasma-shielded, miniature Rogowski probe

FIG. 7: Radial current density profile of the plasma channel for three different values of V_{bias} . The plasma current profiles shown in Fig. 6 are unfolded into a current density profile given by the analytical expression in Eq. 3.